

PRORIL

60Hz

GOVOX-S Series, these vortex pumps are equipped with an agitator, which forcibly agitate the fluid for easy and efficient transmission of sludge, sand, mud, and debris.

Sewage Pump

GOVOX-S 322/337

Vortex and Agitator Pump



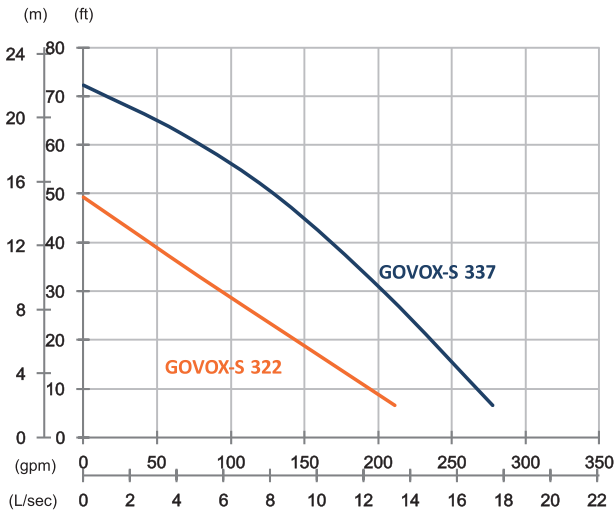

	GOVOX-S 322	GOVOX-S 337
OUTPUT	3 HP (2.2 kW)	5 HP (3.7 kW)
OUTLET	3" (80 mm)	3" (80 mm)
SOLID PASSAGE	0.5" (13 mm)	0.5" (13 mm)
Weight	95 lbs/43 kg	117 lbs/53 kg
HEAD	Rated: 33 ft, 10 m Max: 49 ft, 15 m	Rated: 49 ft, 15 m Max: 72 ft, 22 m
FLOW	Rated: 79 gpm, 5 L/s Max: 211 gpm, 13.3L/s	Rated: 132 gpm, 8.3 L/s Max: 277 gpm, 17.5 L/s

Pump Type		Electric Submersible Pumps
Motor	Phase	3-Phase
	Type	Induction Motor
	Poles	2 Pole (3450 rpm)
	Insulation	Class F
	Protector	Circle Thermal Protector
	Starter	D.O.L.
Lubricant		Food Grade (ISO VG32)
Specs.	Impeller Type	Vortex
	Shaft Seal	Double Mechanical Seal
		Silicon Carbide VS Ceramic/Carbon
	Bearings	C3 Shielded ball bearings
	Cable	CSA-Certified PVC Jacketed Cables
33 ft (10 m) or longer upon request		
Materials	Pump Casing	Ductile Iron
	Impeller	Gray Iron
	Motor Frame	Gray Iron
	Motor Shaft	Stainless Steel
Max. Liquid Temperature		40°C (104°F)
Max. Submersion Depth		20 m (66 ft)
pH Range		pH 5 - pH 8

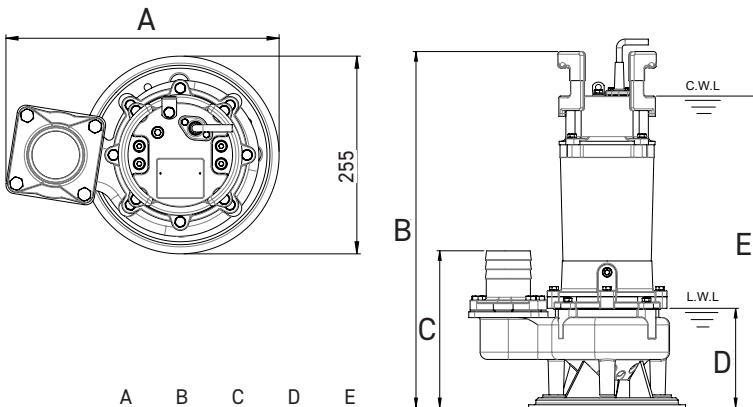

	A	B	C	D	E
GOVOX-S 322	373	665	270	155	636
GOVOX-S 337	383	718	275	160	590

unit : mm
 C.W.L : Continuous running water level
 L.W.L : Lowest running water level